

HOLIDAY ACCOMODATION

THE BROCCHURE 2024



INTEGRATED
WITH NATURE



ABOUT US



Burrowed specialises in creating high quality, eco-friendly, low impact spaces, designed to be integrated within the landscape and surroundings.

Our mission is to create **eco-friendly** structures which can be **integrated in nature**. Our designers are always searching for alternative materials, Burrowed has a team of highly skilled craftsmen working to bring your dream pod to reality.

Using new and innovative technologies we have designed and engineered a revolutionary new building solution using **high density polyethylene (HDPE)**, a lightweight, yet durable material requiring no concrete foundations, minimising environmental impact

Our grass roofed pods have a huge range of environmental benefits, from reduced energy usage (due to natural insulation), to absorption of carbon dioxide, increased biodiversity and proven effects on human wellbeing!

"We wanted a lightweight, yet durable material minimising environmental impact, without the need for concrete foundations."

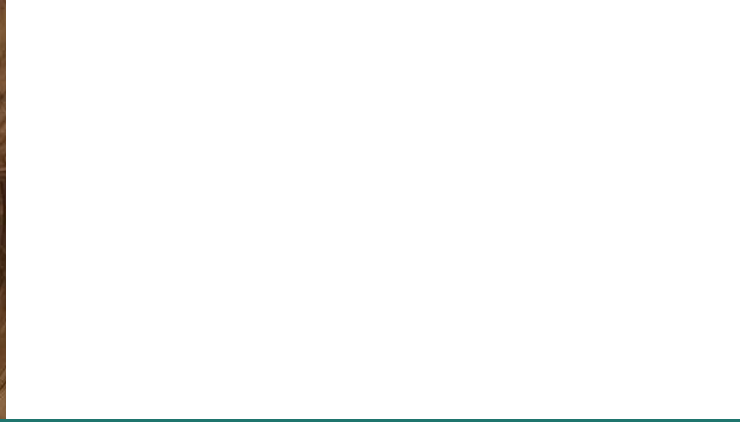

INTEGRATED IN NATURE

We design and build our products to work with nature and your surroundings

Our friendly design team can help to make the most of the landscape

BENEFITS INCLUDE:

Low impact - our structures can be moved leaving no lasting effects on the environment

Planning permission - if required, (e.g. holiday lets) is usually much more easily obtained than with traditional builds

Slopes, banks & underground - structures are perfect for building into slopes or even underground

No foundations - less expense and no damage to the environment



"We are not above nature, we are a part of nature."

*Equal the lifespan of
bricks and mortar*



125 YEAR GUARANTEE

Our unique high density polyethylene structure is guaranteed to last 125 years

Your structure will provide decades of service, although the doors and interior will likely need replacing along the journey and are unfortunately not covered by 125 year guarantee.

Given the extraordinary life span of our products, your pod is an asset which will retain its value as a traditionally built extension would

Moving house? No problem. Simply take your structure with you!



ONE BEDROOM

AYRSHIRE



AYRSHIRE 8M

† Please note: Ayrshire models are subject to 5% VAT this is due to the floor area being less than 23m².

The Ayrshire comes in 2 sizes, 3m x 6m which is perfect for couples and a 3m x 8m which can accommodate 4 persons with the use of a sofa bed.

AYRSHIRE 6M

scale 1:50 @A3



Interior plan

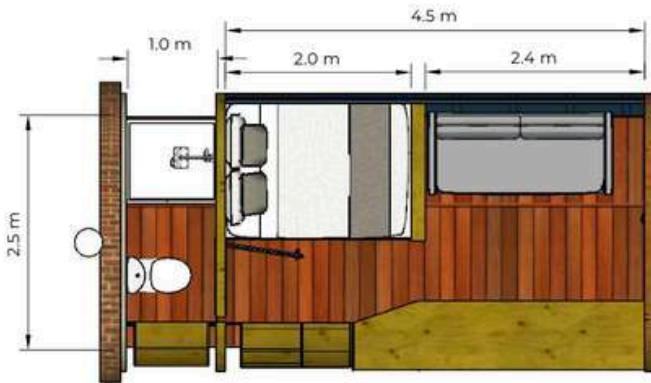

Exterior side

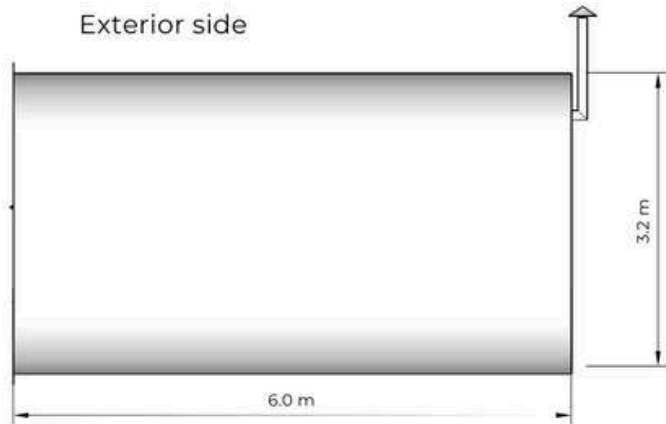

Exterior front

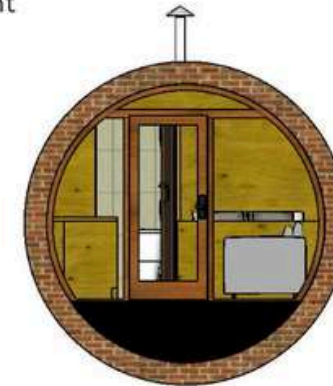
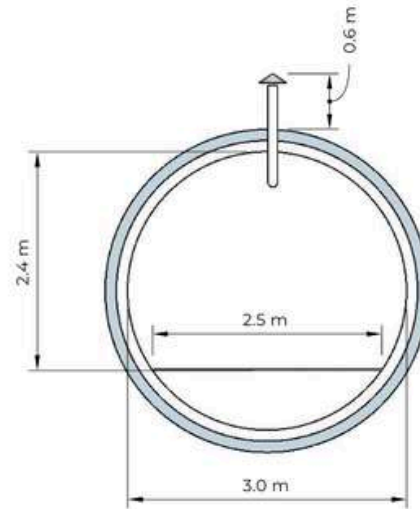

The Ayrshire 6m features one King sized bed, bathroom with sink, toilet & shower.

Kitchenette includes oven, hob, sink and fridge. UPVC Oak front door, underfloor heating, composite flooring, LED downlights, sockets, Bluetooth speakers, sofa, brick panel and painted wall coverings, PVC/Tile bathroom panels.

£46,995 + 5% VAT



AYRSHIRE 8M LAYOUT A

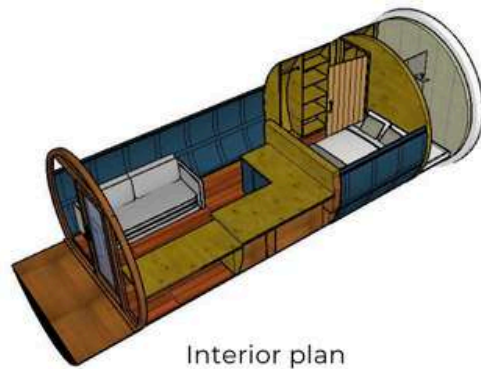

Interior plan

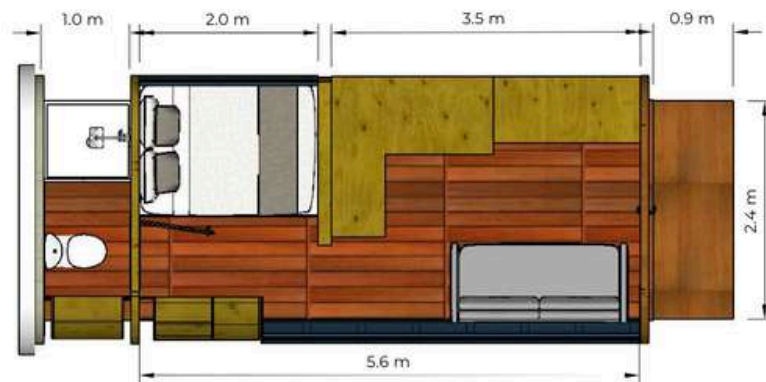

Exterior side

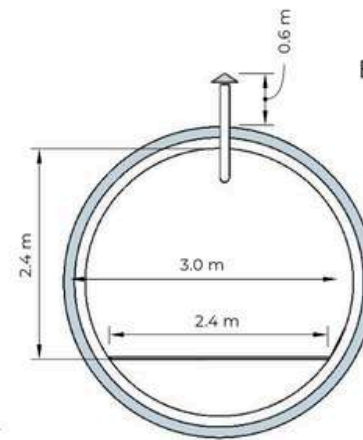

Exterior front

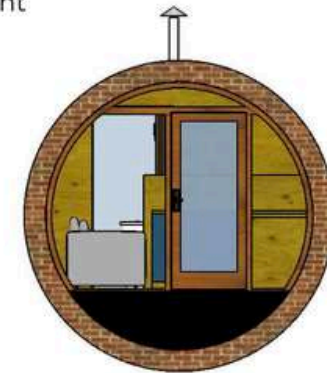

Includes all the same features as the 6m Ayrshire with an additional 2metres in structure length. The extra space is perfect if you want the flexibility for 2 extra people on a comfortable sofa bed and the 8m includes a decked porch. Layout A includes a fixed breakfast bar.

£52,995 + 5% VAT



AYRSHIRE 8M LAYOUT A

AYRSHIRE 8M LAYOUT B

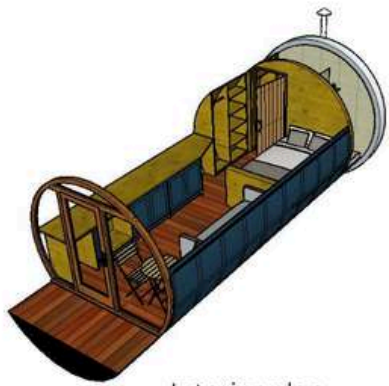

Interior plan

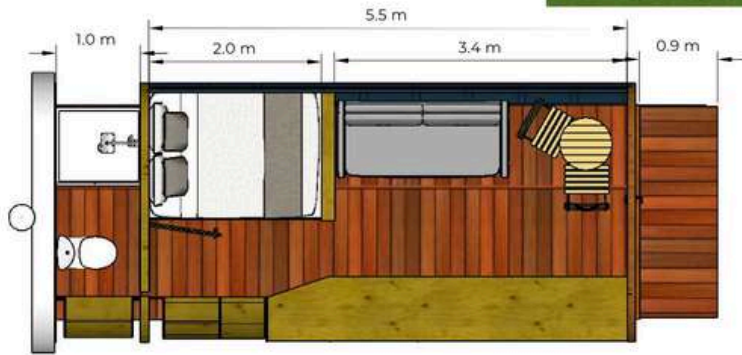

Exterior side

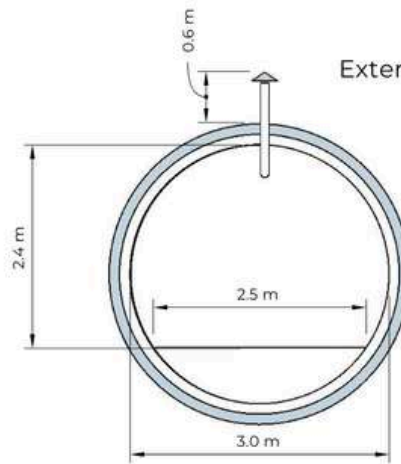
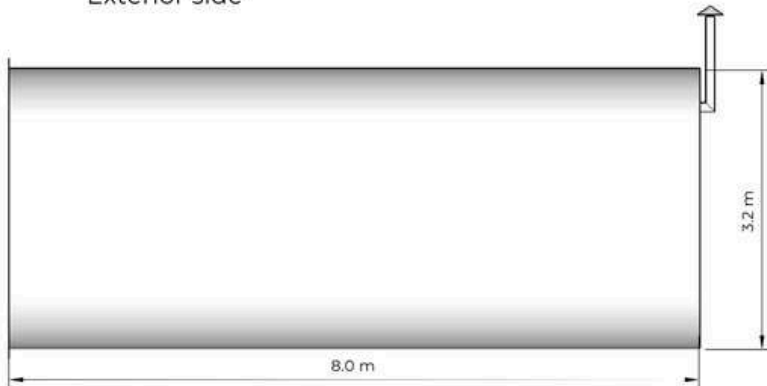

Exterior front

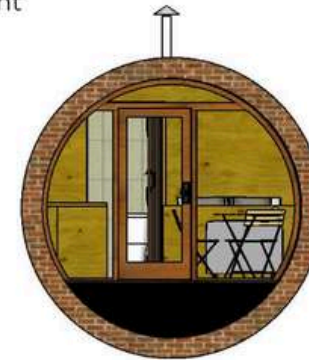

Ayrshire 8m layout B Includes all the same features as 8m layout A, however instead of a fixed breakfast bar this layout allows space for a bistro table and chairs to take advantage of the views.

This layout also includes additional kitchen storage space.

£52,995 + 5% VAT

ONE BEDROOM

OXFORDSHIRE



The Oxfordshire is a one bedroom with side entrance making it quirky and attractive. Sleeps 4 with the use of the sofa bed.



OXFORDSHIRE

scale 1:75 @A3

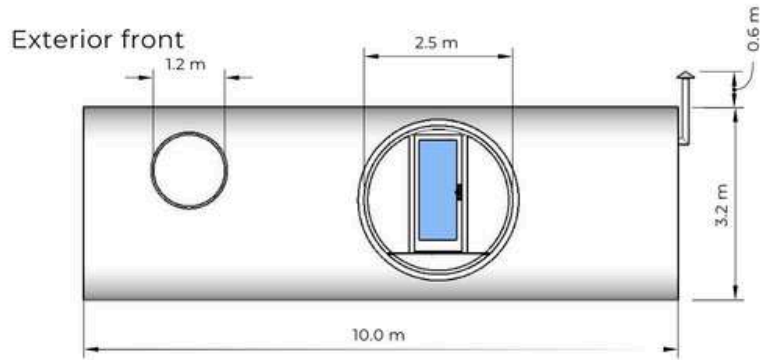
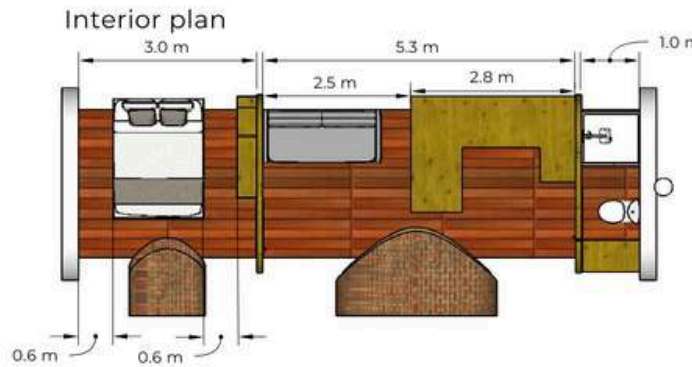
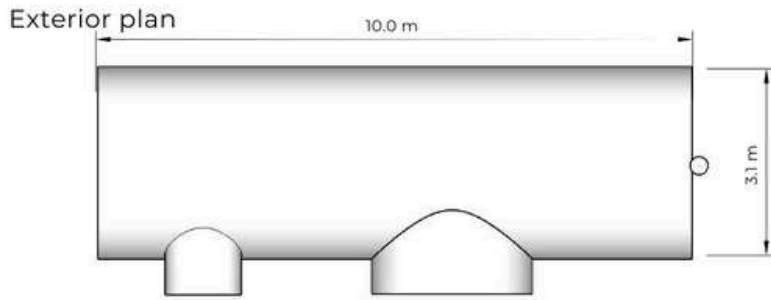
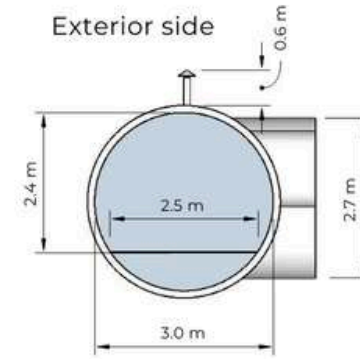
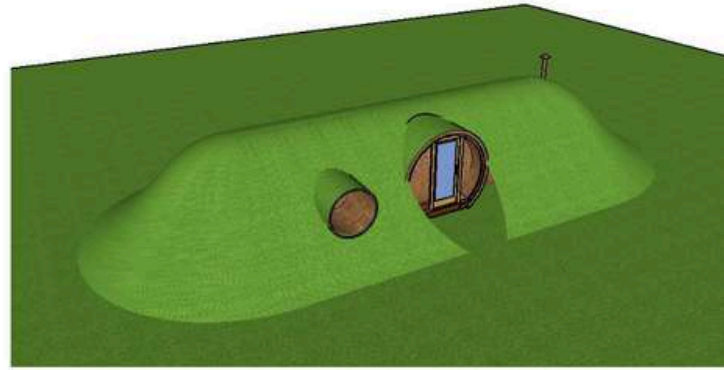
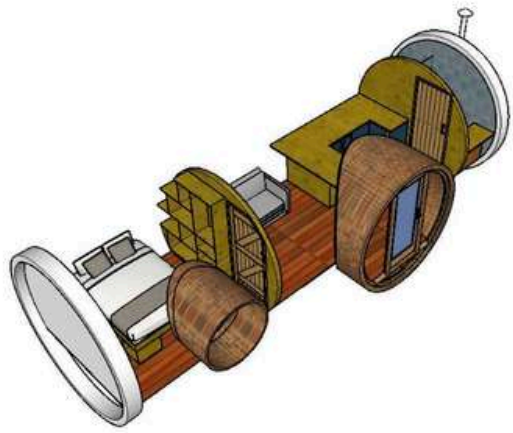

One King sized bedroom, open plan kitchen, dining & living area.

Bathroom includes sink, toilet & shower.

Sofa bed sleeps additional 2 adults.

Large kitchen & breakfast bar, composite flooring, underfloor heating, LED downlights, Bluetooth speakers, UPVC Oak front door, 1200mm port hole window, brick panel and painted wall coverings, composite bathroom panels.

£89,995 0% VAT



RUSTIC OXFORDSHIRE

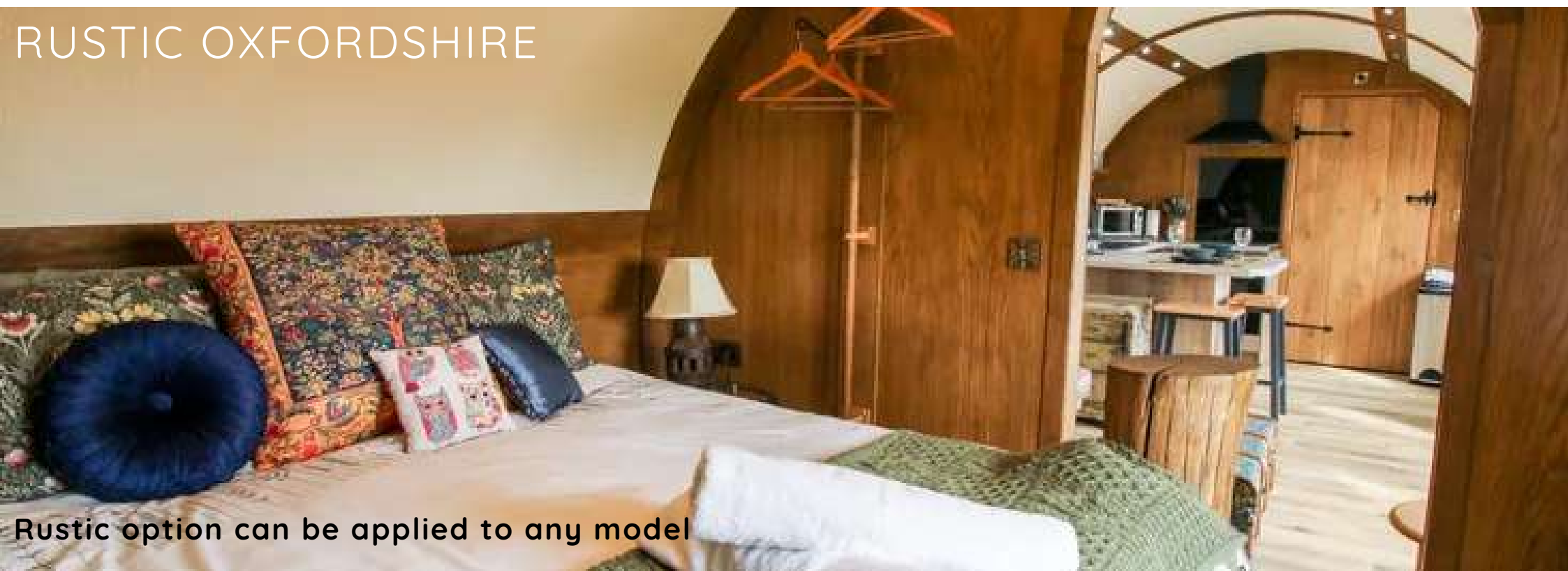

Rustic option can be applied to any model

TWO BEDROOM

DEVONSHIRE



The Devonshire is perfect for families or sharing with friends. Two king sized bedrooms both with on suite bathrooms and can sleep up to 6 persons including the use of the sofa bed.



DEVONSHIRE

DEVONSHIRE

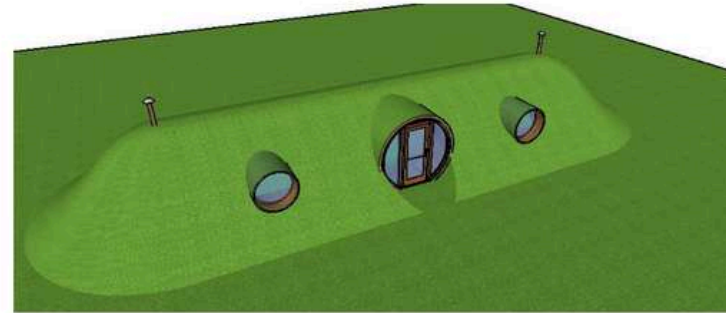
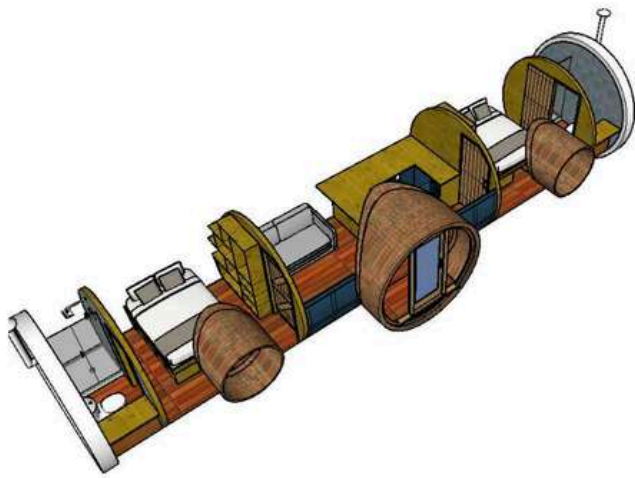

Exterior side

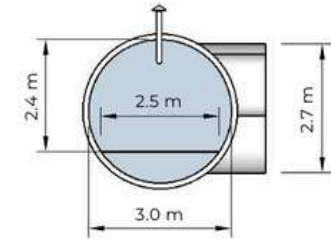

Exterior plan

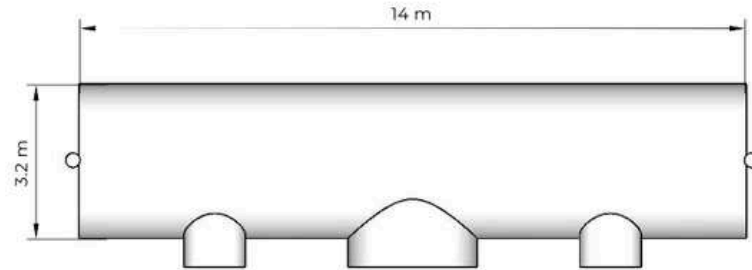

Interior plan

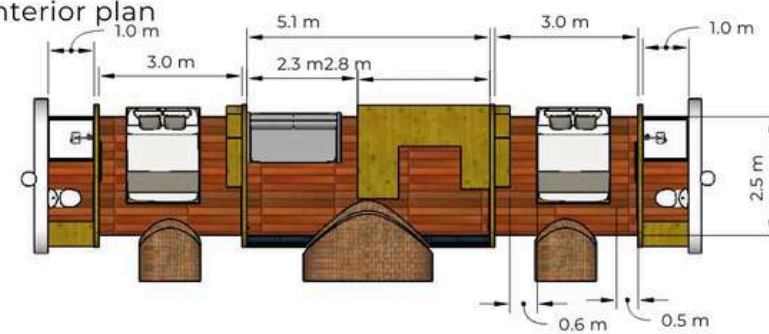

Exterior front

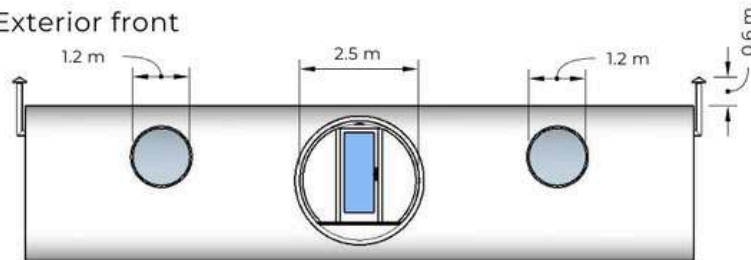

2 King sized bedrooms each with en suite bathrooms (sink, toilet & shower)
Large kitchen & breakfast bar, sofabed, composite flooring, underfloor heating, LED downlights, Bluetooth speakers, UPVC Oak front door, 2 port hole windows, brick panel and painted wall coverings, composite bathroom panels.

£109,995 0% VAT

THREE BEDROOM

HAMPSHIRE



The Hampshire is our flagship model, ideal as a luxury home or holiday let. At 3m x 14m with a 6m elbow it is spacious, quirky and attractive and sleeps up to 8 persons including use of the sofabed.



HAMPSHIRE

HAMPSHIRE

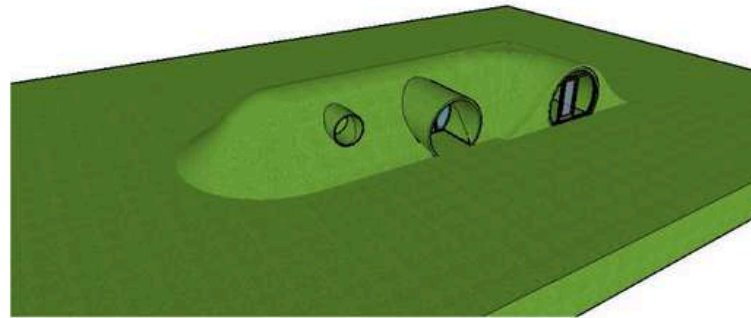
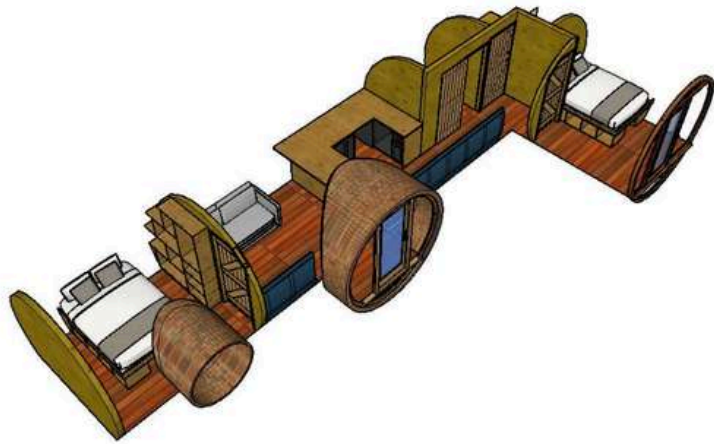

Exterior side

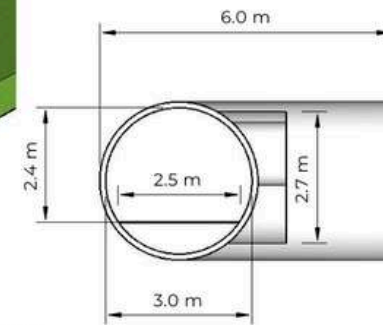

Exterior plan

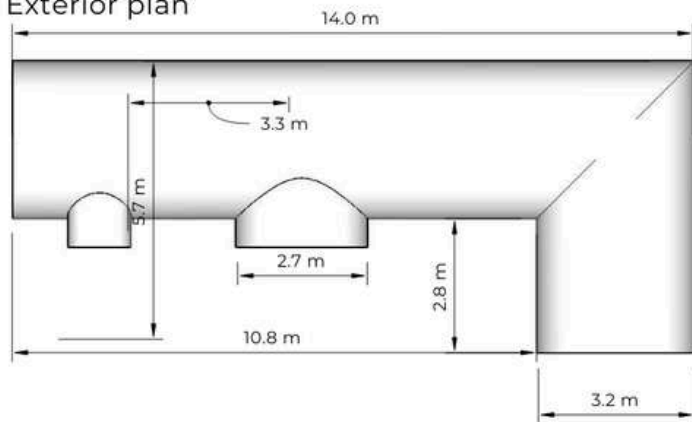

Exterior front

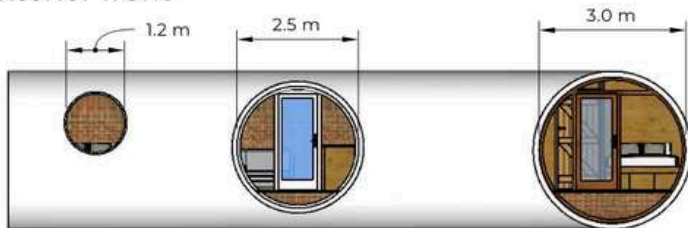

Interior plan

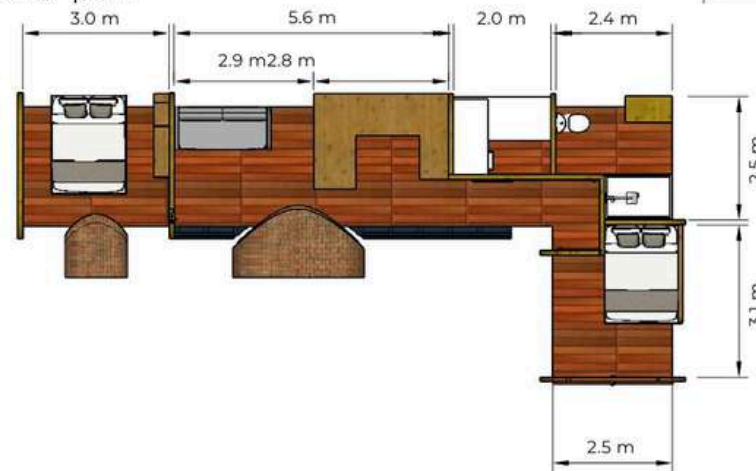

3 bedrooms includes 2 king sized bedrooms and a 2 separate sleeping pods perfect for children (double and single)
 Large family bathroom with sink, toilet and shower, PVC/Tile & brick bathroom.

Stylish kitchen & breakfast bar, double sofa bed, underfloor heating, composite flooring, LED downlighting, Bluetooth speakers, UPVC Oak front door & glazed bedroom wall with separate entrance.
 1200mm port hole window, brick, panel and painted wall coverings.

£139,995 0% VAT



HAMPSHIRE



ATTENTION TO DETAIL

High quality electrical fittings & brick slip wall-coverings



Port hole windows



Skylight £2495

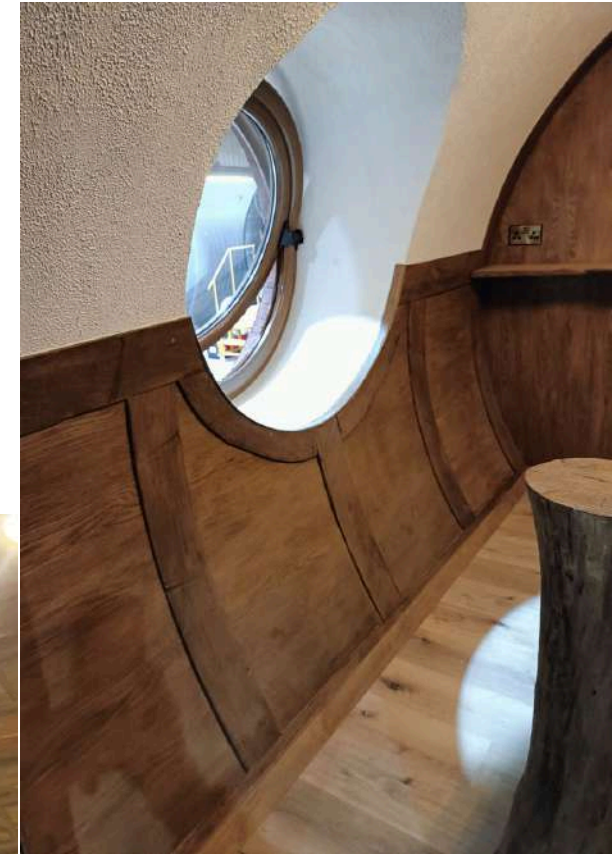

and beautiful woodwork

At Burrowed, we're especially proud that all our structures are manufactured from HDPE, a light, yet durable material which does not require traditional concrete foundations

Our structure can be enrobed in grass, wildflower or sedum.

Did you know? 1 square metre of green roof can absorb the carbon dioxide produced by an average car driving 50 miles!



Grass roofs also: absorb airborne particles, reduce rainwater run-off, protect underlying structures from UV, act as natural heat insulators and provide sound insulation too

VISIT US

Burrowed Ltd
North Laithes Farm
Wellow Lane
Eakring
Newark
NG22 0AN

Tel. 01623 869432

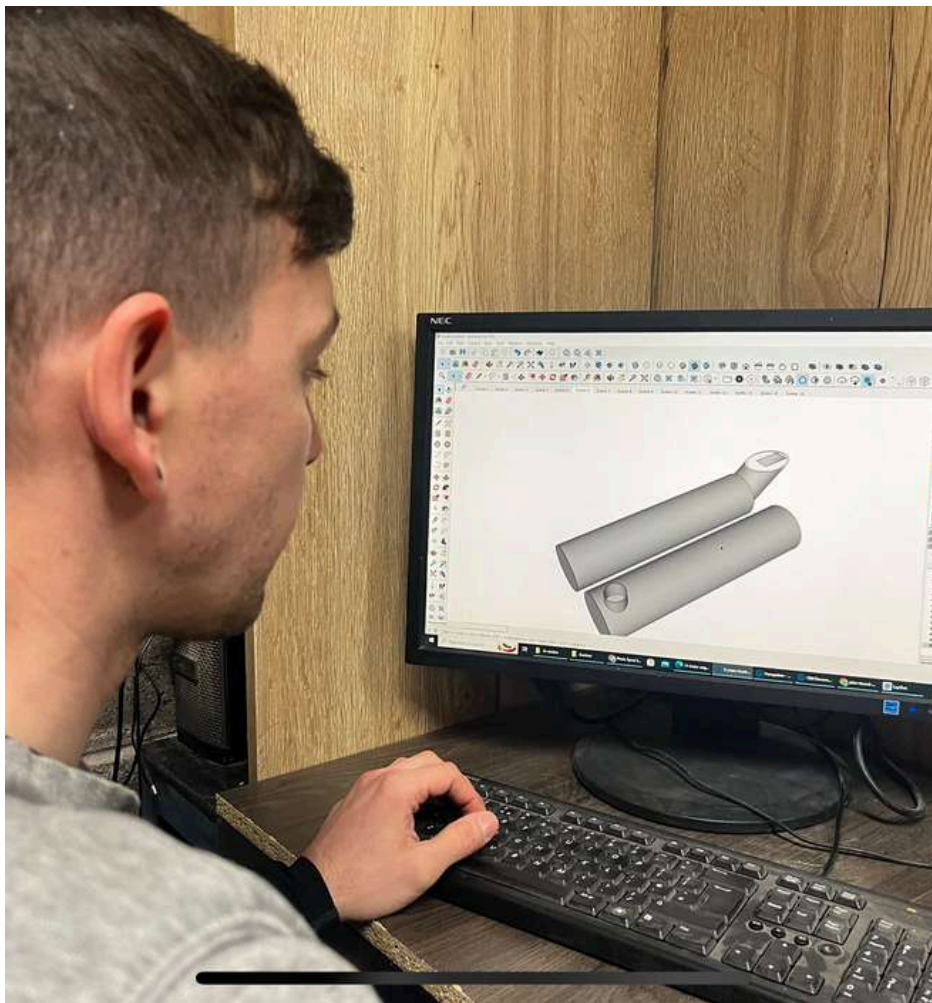

Don't take our word for it! Come and see for yourself. We can arrange visits to view ongoing projects at our Boughton workshops.

